

Waste storage vent system

P-86

The waste management system controls and disposes of waste solids, liquids, and gases. The major portion of the system is in the right-hand equipment bay. The system stores feces, removes odors, dumps urine overboard, and removes urine from the space suit.

Urine, oxygen, and fecal odors, as well as emergency relief of fluids from the CM batteries and excess water from the water system, are routed overboard through the water/urine dump line. A small (0.055-inch) nozzle restricts gas flow to 0.4 cubic feet per minute and liquid flow to 1 pound per minute. The limited gas flow prevents excessive loss of cabin atmosphere during fecal canister use. The liquid flow is restricted to prevent the formation of ice in the nozzle. Redundant heaters at the nozzle also help prevent ice.

The urine subsystem contains urine collection bags, a 100-inch flexible hose (capable of reaching the crewman in a couch) with a 3/8-inch suit urine valve quick-disconnect, and controls. The urine collection bag connects to the flexible hose at one end and to a hold-on cuff at the other. The rubber cuff is rolled onto the penis. The flexible hose can withstand a 5-psia differential pressure.

The fecal subsystem has 30 bag assemblies and tissue dispensers. The bag assemblies have inner and outer fecal-emesis bags with pouches containing a germicide and a skin-cleaning towel. The rim of the inner bag is covered with a cement-like material covered with a thin plastic. For use, the plastic is peeled off and the bag "pasted" to the buttocks. After use, the germicide is inserted in the inner bag and the latter is sealed in the outer bag and kneaded. The sealed bags are stowed in the waste disposal compartment; a split membrane trap prevents the bags from floating through the door into the cabin when the door is open. Tissue dispensers contain tissue (Kleenex) for wiping and are stored in a container under the center couch.

OPERATIONAL AIDS

These include data files, tools, workshelf, cameras, fire extinguishers, oxygen masks, and waste bags.

The crew has a data file containing checklists, manuals, and charts needed for operation of the spacecraft. At launch the data file is stored in a compartment in the right-hand forward equipment bay. Data books used by the LM pilot are stored in

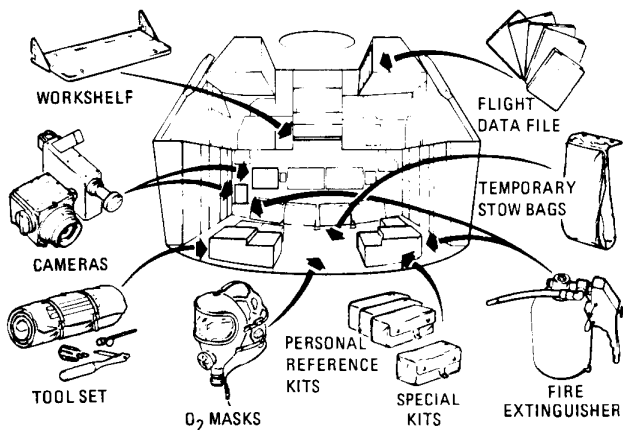

Operational aids

P-87

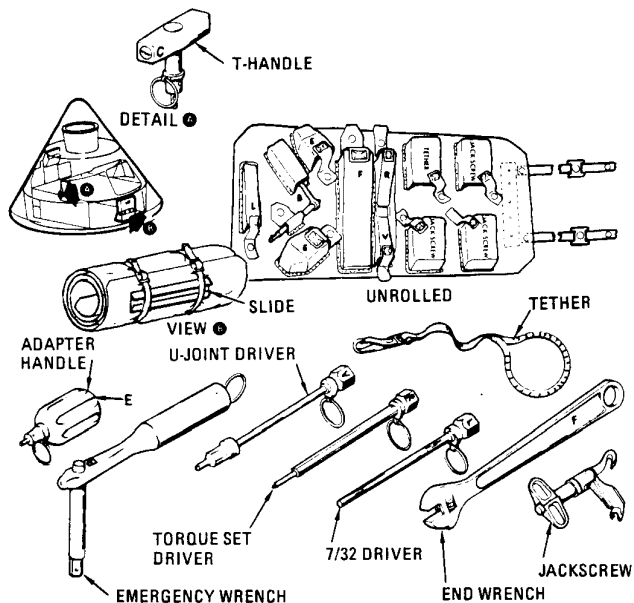

P-88

Tool kit

a container at his right side during flight. The files contain such things as the flight plan, mission log, landmark maps, star charts, and subsystem data.

The tool set holder is a synthetic cloth pouch which contains pockets for a number of tools. It rolls for stowage (on the aft bulkhead) and has snaps on the back so it can be attached to the CM structure. Among the tools in the set are an adjustable wrench, an adapter handle, hatch securing tools, two drivers, and a 20-inch tether. Placards throughout the CM indicate which tools are to be used and the direction of rotation.

The astronauts will have still and movie cameras in the CM. The movie camera is a 16mm Maurer sequence camera that operates at 6 frames per second, 1 frame per second, single frame, and time exposure. Accessories include 18 and 5mm lenses and a right-angle mirror. The camera is powered by the spacecraft's dc system and can be mounted to the CM structure. The still camera is a 70mm Hasselblad. It is hand-held and manually operated, and has a ring sight and an 80mm lens. An exposure meter and a spotmeter also are provided.

The CM has one fire extinguisher, located adjacent to the left-hand and lower equipment bays. The extinguisher weighs about 8 pounds, is about 10 inches high, and has a 7-inch nozzle and handle. The tank body is a stainless steel cylinder with a dome. The extinguishing agent is an aqueous gel expelled in 2 cubic feet of foam for approxi-

mately 30 seconds at high pressure. The expelling agent is Freon. Safety features prevent sparking and over-heating. Fire ports are located at various panels so that the extinguisher's nozzle can be inserted to put out a fire behind the panel. The fire extinguishers are produced by Southwest Research Co., San Antonio, Tex.

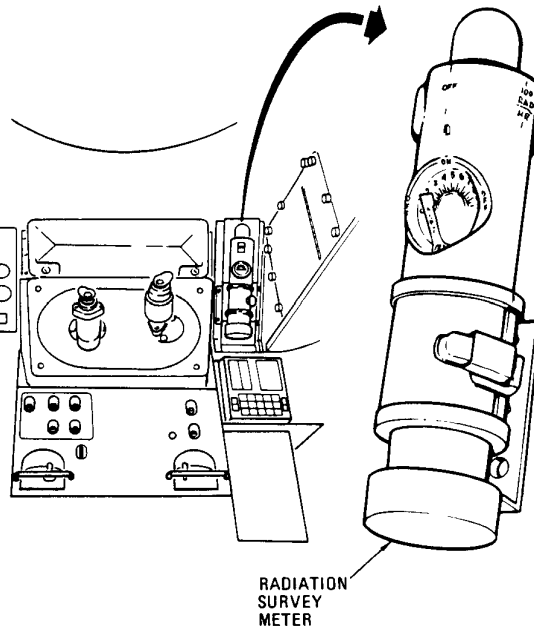
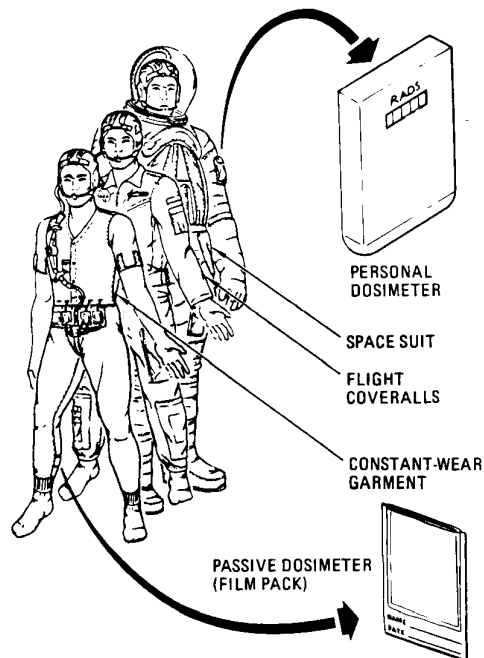

P-89

Radiation measuring and monitoring units

Oxygen masks are provided for each astronaut in case of smoke, toxic gas, or other hostile atmosphere in the cabin while the astronauts are out of their suits. The masks are a modified commercial type with headstraps. Oxygen is supplied through a flexible hose from the emergency oxygen/repressurization unit in the upper equipment bay. The masks are stowed in a cloth bag in the aft equipment bay below the emergency oxygen unit.

MEDICAL SUPPLIES

Medical equipment aboard the command module includes monitoring devices and emergency supplies.

The sensors attached to each crewman are the principal monitoring devices. These sensors are connected to signal conditioners which fit into pockets on the bioinstrumentation belt. The signal conditioners (somewhat smaller than a cigarette package and weighing about 2 ounces) amplify the low-level signals from the sensors, and transmit them to an electrocardiograph and an impedance pneumograph (which measures respiration rate).

A number of devices are used to monitor radiation level. These include passive dosimeters, personal radiation dosimeters, a radiation survey meter, a Van Allen Belt dosimeter, and a nuclear particle detection system.

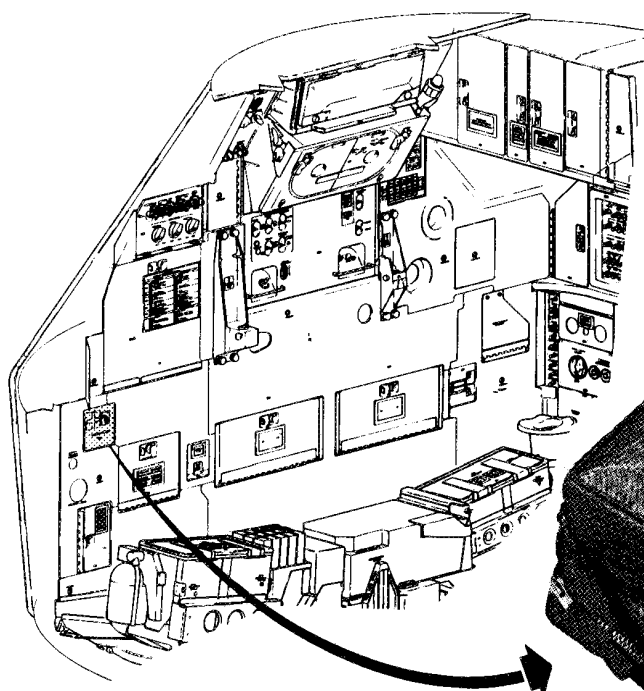

- CONTENTS:
- PAIN INJECTORS
 - MOTION SICKNESS INJECTORS
 - COMPRESS
 - BAND AIDS
 - SKIN CREAM
 - ANTIBIOTIC OINTMENT
 - EYEDROPS
 - PAIN PILLS
 - STIMULANT PILLS
 - ANTIBIOTIC PILLS
 - MOTION SICKNESS PILLS
 - DIARRHEA PILLS
 - DECONGESTANT PILLS
 - ASPIRIN
 - ELECTRODES
 - ELECTRODE PASTE
 - MICROPORE DISCS
 - STOMACHEAL DISCS
 - THERMOMETER
 - TEST PAPER
 - ROLL-ON CUFFS

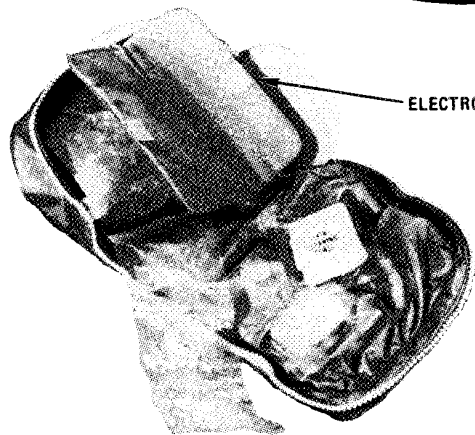

ELECTRODES



Medical supplies

P-90

Each crewman wears four passive dosimeters (film packs) in pockets at the temple, chest, thigh, and ankle. These register total radiation dosage and are processed on the ground after the mission. Each crewman also wears a personal radiation dosimeter which is battery-powered and about the size of a cigarette package; it has a readout which indicates the total dosage received during the mission.

The radiation survey meter determines the magnitude of the immediate radiation field; it is flashlight-like about 10 inches long and 2 inches in diameter. It is battery-operated and is clamped to a bracket near the guidance and navigation station in the lower equipment bay.

The Van Allen Belt dosimeter measures dose rates to the skin and blood-forming organs (depth dose measurement). It consists of two individual dosimeters (skin and depth) which have ionization chambers as sensors; the measurements of the sensors are telemetered to the ground. This is mounted in the structure of the CM near the hatch.

The nuclear particle detection system (produced by Philco Corp's Western Development Laboratory, Palo Alto, Calif.) measures proton and alpha particle rates and telemeters the information to the ground. It is normally located in the area between the command and service modules that is enclosed by the SM-CM fairing.

Medical supplies are contained in an emergency medical kit, about 7 by 5 by 5 inches, which is stored in the lower equipment bay. It contains oral drugs and pills (pain capsules, stimulant, antibiotic, motion sickness, diarrhea, decongestant, and aspirin), injectable drugs (for pain and motion sickness), bandages, topical agents (first aid cream, sun cream, and an antibiotic ointment), and eye drops.

SURVIVAL EQUIPMENT

Survival equipment, intended for use in an emergency after earth landing, is stowed in two rucksacks in the right-hand forward equipment bay. The rucksacks are 18 inches long, 6 inches wide, and 6 inches deep and weigh about 54 pounds.

One of the rucksacks contains a three-man rubber life raft with an inflation assembly,

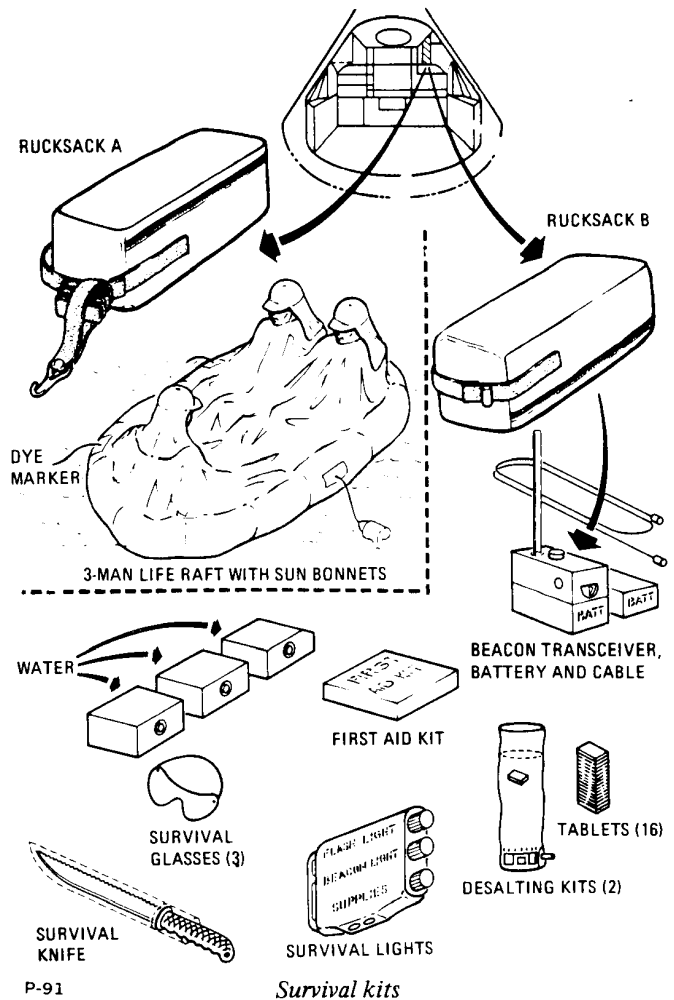

carbon-dioxide cylinder, a sea anchor, dye marker, and a sunbonnet for each crewman.

The other rucksack contains a beacon transceiver, survival lights, desalter kits, machete, sun-glasses, water cans, and a medical kit.

The UHF beacon transceiver (manufactured by Sperry Phoenix Co.) is a hand-held battery-powered radio tuned permanently to a VHF frequency of 243 megacycles. The receiver-transmitter and battery pack form a watertight assembly about 8 by 4-1/2 by 3 inches; a tapered, flexible steel tape antenna can be extended to 11-1/2 inches. The transceiver unit can be used for voice communications through a speaker and microphone or as a beacon, in which case it will transmit an intermittent signal for up to 24 hours. A spare battery and a spacecraft connector cable are provided.

The survival lights are contained in a waterproof, three-in-one device. The unit has a flashlight, a strobe light for night signaling, and a waterproof compartment containing fish hook, line, a sparky kit (striker and pith balls), needle and thread, and a whistle. The top of the unit is a compass with a folding signal mirror on one side.

The two desalter kits contain a process bag, tablets, and bag repair tape. The bag is plastic with a filter at the bottom and holds about a pint. Sea water is put into the bag and a tablet added; after about an hour the water can be drunk through a valve on the bottom.

The machete (protected with a cloth sheath) is very thin with a razor edge on one side and a saw edge on the other. The three sunglasses are polarized plastic sheet with a gold coating that reflects heat and radio waves. The three water cans are aluminum, hold a little more than a half-gallon each, and have a drinking valve.

The survival medical kit contains the same type of supplies as the emergency medical kit: 6 bandages, 6 injectors, 30 tablets, and one tube of all-purpose ointment.

EQUIPMENT

Bioinstrumentation Harness — Sensors are attached to bodies of each crewman with paste and tape to monitor heartbeat (electrocardiogram) and respiration (impedance pneumograph). The assembly includes three signal conditioners (cigarette package size) and accessories located in the medical accessories kit.

Cameras — There are a 16-mm Maurer sequence camera and a 70-mm Hasselblad camera. Accessories for the Maurer are an 18-mm lens, a right angle mirror, power cable and film magazines. The camera weighs about 1.9 pounds and each magazine, 1/2 pound. Ten to 15 magazines are carried. It is electrically operated on 28 volts dc. Normally, it is mounted on the right rendezvous window frame. There are two electrical outlets in the cabin from which it can be used as a hand-held camera to take sequential pictures of crew activity. It is also used to show docking and rendezvous movies and any other sequential operation. It can be operated at speeds of six or one frame per second, or for test, single frame or time exposure. The 70-mm Hasselblad is hand-held and has an

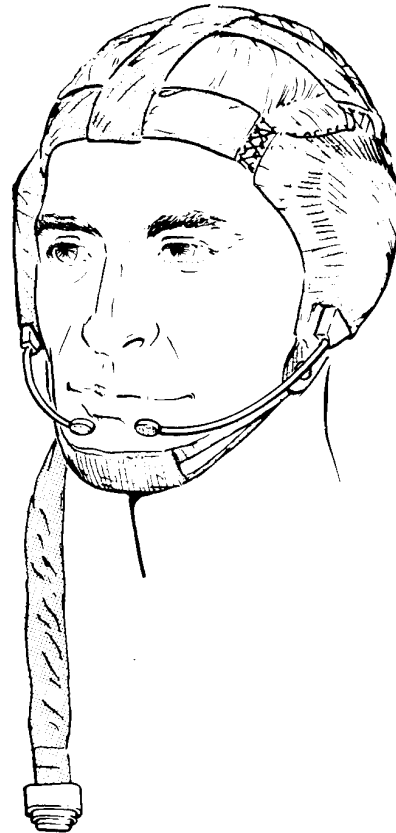

P-92

Communications soft hat

80-mm Zeiss planar lens and a ring sight. The camera weighs 1.9 pounds and each of five cassettes weighs 1.59 pounds. Each cassette has 150 exposures. This camera will be used for high-resolution photography. It will verify landmark tracking; record third-stage Saturn separation; photograph disturbed weather regions (hurricanes, typhoons etc.) debris collection on spacecraft windows, other equipment in space, the lunar module during rendezvous and docking, the terrain of the moon, and act as a back up to the 16-mm camera. The cameras are stowed in the lower equipment bay.

Communications Soft Hat — It has two earphones and two microphones, with voice tubes, on two mounts that fit over the ears. It is made of cloth and plastic. There are three straps attached to the mounts with laces for individual fitting. A chin strap secures it to the head. A small pocket on the inside near the right temple holds a passive dosimeter film packet. An electrical cable with a 21-socket connector will connect to the constant-wear garment adapter or the space suit. The hat is worn at all times for the purpose of

communications.

Constant Wear Garment (David Clark Co.) – This is a 13-ounce undergarment for the space suit. It is a porous cotton cloth, one-piece garment similar to long underwear. It has a zipper from the waist to the neck and openings for urination and defecation. There are snaps at the midsection to attach the biomedical belt with signal conditioners, and pockets for film packet passive dosimeters at the ankles, thighs, and chest. The garment also has integral socks. Each crewman will wear one garment and will have another garment stowed in a locker on the aft bulkhead bay.

Couches (Weber Aircraft, Burbank, Calif.) – The three crew couches (left, center, and right) are made of steel framing and tubing and covered with Armalon, a heavy glass fiber cloth impregnated with Teflon. The couches are clamped together and weigh 280 pounds. They are suspended and supported by eight attenuator struts, and each couch is adjustable. The backpan of each couch is 32 by 22 inches and is concave. Headrests can be moved 6-1/4 inches up and down to adjust for crewman height. The hiprest and upper legrest form the seat of the seatpan. The seatpan also has a footrest, which engages the boot heel and holds it in place. The couch seats are adjustable to a number of positions, but the ones used most are 85 degrees (for launch, orbit, entry, and landing), 170 degrees (when crewmen want to get to lower equipment bay), and 11 degrees (when crewmen want to get to right, left, and lower equipment

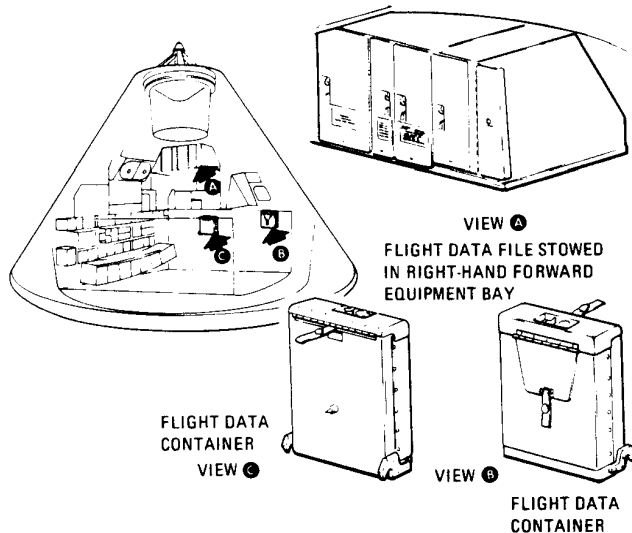

P-93

Flight data file

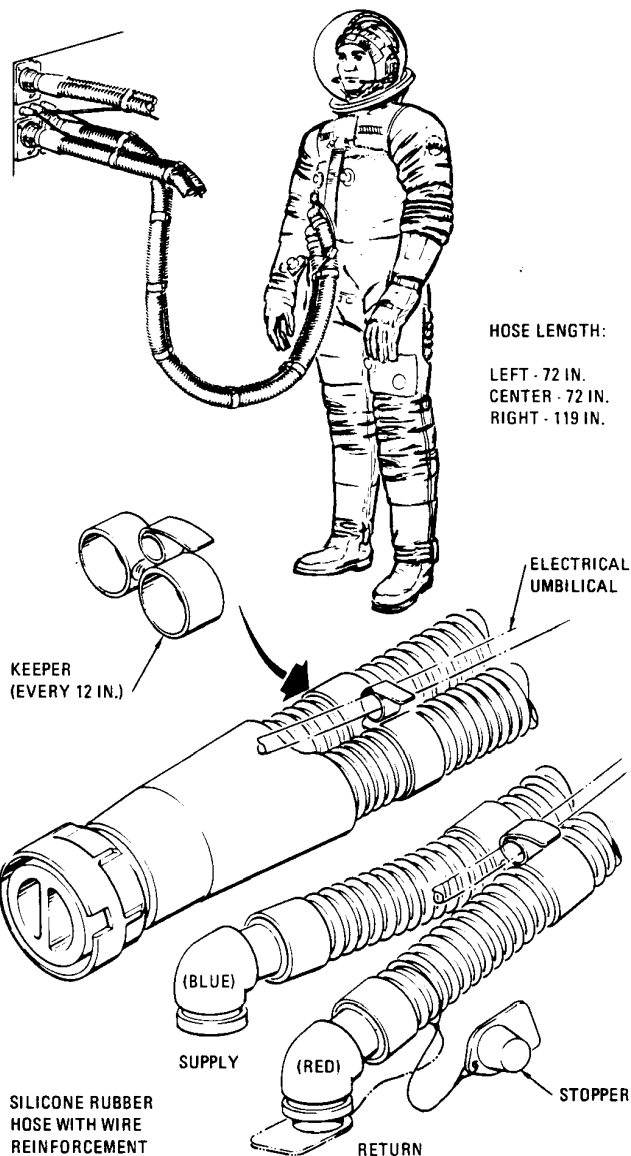

P-94

Oxygen hose assembly

bay storage areas). It can also be adjusted to 270 degrees for lower equipment accessibility. Positions are indicative of the angle of the seatpan (which is movable) to the backrest.

Crewman Umbilical Assembly – Cable and hose assembly is connected to the space suit – the cable for electrical power for communications equipment and the hose for oxygen. There are three oxygen hoses made of Fluorel, or silicon rubber in a fiberglass cloth sock. Two of the hoses are 72 inches long with a diameter of 1-1/4 inches and weigh 5.3 pounds each. The third, used for transfer to the lunar module, is

119 inches long with a diameter of 1-1/4 inches and weighs 8.2 pounds. The communications cables are Fluorel-covered and consist of a cable and control head. Two are 74 inches long with a 3/8-inch diameter and weigh 2.5 pounds each. Two others, one of which is a spare, are 121 inches long with a 3/8-inch diameter and weigh 3.5 pounds each.

Data Files – There are 20 volumes, containing all reference data for the mission, including checklists, light plans, photo logs, star charts, lunar and earth landmark maps, orbital map, malfunction procedures, and crew logs. They weigh a total of 20 pounds and are stored in the right-hand forward equipment stowage compartment.

Emergency Oxygen Mask and Hose (Darling Co.)

Each crewman has a mask to wear in case of smoke, toxic gas, or other hostile environment when he is in shirtsleeves. Total weight for masks and hoses is 4 pounds. The masks are stowed in a Beta cloth bag on the aft bulkhead below the emergency oxygen/repressurization unit.

Fire Extinguisher (Southwest Research Co.) –

There is one extinguisher stowed in the lower equipment bay beside a CO₂ absorber container. It weighs about 8 pounds, is 10 inches high, and has a 7-inch flexible nozzle and a handle both of which are insulated. It is a stainless steel cylinder with dome containing 2 cubic feet of aqueous gel foam at 6 pounds per square inch. It is activated by pulling a pin and pressing a button.

Flight Coveralls – This is a two-piece Beta Cloth garment with a pair of booties. The coveralls and booties weigh 3 pounds. The coveralls are worn over the constant wear garment and provide additional warmth as well as stowage for miscellaneous personal equipment while in a shirtsleeve environment. The booties are cloth fabric boots with snaps at the ankles. They have Velcro patches at the balls of the feet.

Medical Accessories Kit – Beta cloth bag, about 7 by 5 by 5 inches, has two zippers for access to oral drugs and pills, injectable drugs, dressings, creams and ointments, and bioinstrumentation accessories. The kit weighs 2.5 pounds and is in the lower equipment bay.

Nuclear Particle Detection System – This consists of a detector assembly in the form of a telescope

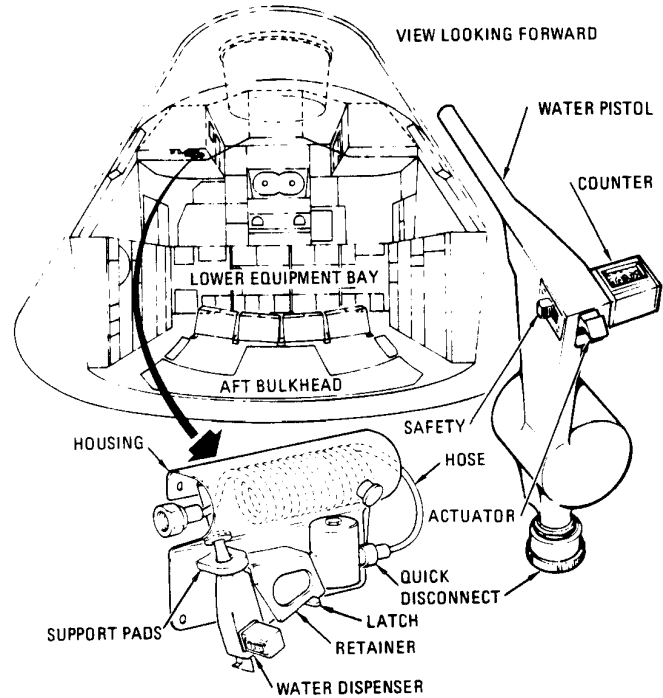

P-95 *Water metering dispenser assembly*

and a signal analyzer assembly. The pulse rates from the detector assembly at which particles enter the various energy intervals are converted to d-c voltage levels by ratemeters in the signal analyzer; the outputs of the ratemeters are then telemetered to ground. The system measures proton and alpha particle rates in four proton and three alpha differential energy bands and one integral proton energy band. The unit is in the adapter section between the command and service modules and is mounted on the forward bulkhead of the service module.

Passive Dosimeters – Each crewman wears three of the radiation-measuring devices, which are processed after recovery to determine total dosage received. They are in form film packs and are worn in constant wear garment pockets at the chest to simulate a 5-centimeter depth to measure bone marrow dosage and at the thigh and ankle to measure skin dosage. Each weighs about half an ounce.

Personal Dosimeters – Each crewman wears a battery-powered radiation dosimeter about the size of a cigarette package in the pocket of a sleeve of the space suit or flight coveralls. Its readout dial will indicate in rads accumulated dosage of radiation received by the crewman during the mission. The dosimeter weighs half a pound.

Personal Hygiene — Each crewman has a toothbrush, 4-by-4-inch wet and dry cleansing cloths, and a tube of ingestible toothpaste, items that are packaged with the food. The wet cloths are saturated with a germicide and water. Towels, 12 by 12 inches and similar to washcloths, will be packaged in containers and stowed in an aft bulkhead locker.

Pilots Preference Kits — Each crewman has an 8 by 4 by 2-inch Beta cloth bag for personal items. The bags are kept in an aft bulkhead stowage locker.

Radiation Survey Meter — It is a 1.58-pound cylinder 10 inches long and 2 inches in diameter. It measures the magnitude of the immediate radiation field. It has an on-off switch, a direct readout dial calibrated in rads per hour, and is battery operated. The meter is clamped in a bracket mounted on the guidance and navigation signal conditioning panel. It is transferred to the lunar module during crew transfer.

Restraints — Gravity-load restraints are three harnesses (one for each crewman) to hold crewmen in their couches; two handholds, and a hand bar. Each restraint harness has a lap belt and two shoulder straps connected at a lap belt buckle. The lap belt buckle is a lever-operated, three-point release mechanism. The strap ends and buckle have snap fasteners and they can be fastened to mating snaps on the couch and struts when not in use. The handholds are strong aluminum handles, one on each longeron by the side windows. The hand bar is near the side hatch and can be stowed or extended. A crewman can hold it with two hands for ingress or egress from the command module side hatch. Zero-gravity restraints are five hand straps behind the main display console, one on the left-hand equipment bay, and one on each lower x-x axis strut.

Sighting Aids — Each of the command module's five windows has an aluminum sheet window shade held on by wing latches. They are .20-inch thick with .250-inch frames and are stowed in a stowage bag in the upper equipment bay. There are two mirror subsystems: internal and external. Each couch has a 4-by-6-inch metal internal viewing mirror assembly consisting of a mounting base, a two-segmented arm, and a mirror. The mirrors for the left and right astronauts are

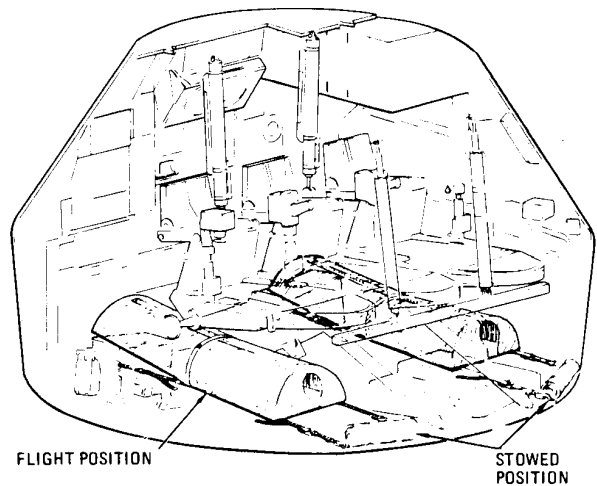
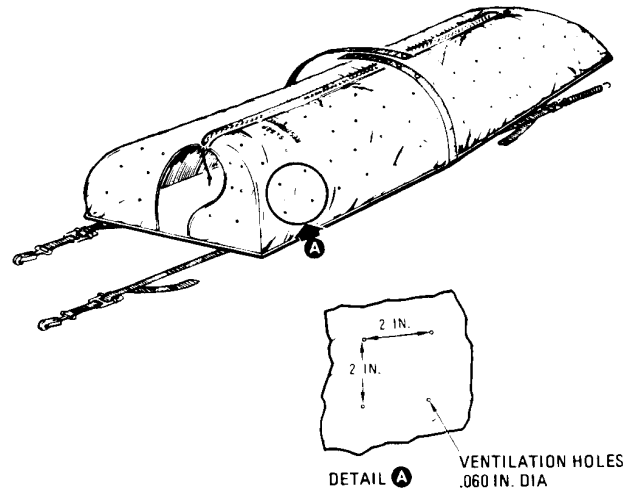

P-96

Sleep station restraints

mounted on the side of the lighting and audio control console above the side viewing window; they have folding joints. The center astronaut's mirror is mounted on the right-hand upper x-x axis attenuator strut. External viewing mirrors, which also are metal, consist of an upper mirror assembly mounted on the side wall near the upper rim on the right rendezvous window frame and a lower mirror assembly mounted on the right rendezvous window housing near the lower rim of the window frame. A mirror assembly is a mirror and a bracket.

Sleeping Bags — There are two Beta-cloth sleeping bags weighing 2.5 pounds each. They are 64 inches long with a 7-inch diameter neck opening when the bag is zippered closed. There is a torso zipper opening. The bags have holes for ventilation every 4 inches. The bags are under the left

and right couches for sleeping. At launch, they are rolled and strapped against the upper side wall and aft bulkhead.

Survival Kit — The kit is stowed in the right-hand forward equipment bay in two rucksacks, which are Beta cloth zippered bags. Both rucksacks are 18 by 6 by 6 inches. One, which weighs 34.8 pounds, contains a VHF beacon-transceiver which is a hand-held, battery-powered radio fixed-tuned to a VHF frequency of 243 megacycles; it is manufactured by Sperry Phoenix Co. The receiver-transmitter and battery pack assemblies mate to form a water-tight 8-by-4-1/2-by-3-inch unit. The antenna is an 11-1/2-inch tapered flexible steel tape ending in a coaxial RF connector and is normally stored in a retaining spool and clipped on top of the radio. The rucksack also contains a spare battery and spacecraft connector cable; a survival light unit containing a flashlight, a strobe light for night signaling, a fish hook and line, a sparky kit (striker and pith balls), needle and thread, whistle, compass, and a folding signal mirror; plastic desalter bag with a filter at the bottom; desalter tablets; desalter bag repair tape; one machete protected with a cloth sheath (the knife has a razor edge and the back edge is a saw); three pair of sunglasses that are a polarized plastic sheet with Sierra Coat III — a gold coating that reflects heat and radio waves — to protect eyes against the sun and glare; three 5-pound capacity aluminum water cans; and medical kit with 6 Band-Aids, 6 injectors, 30 tablets, and one tube of all-purpose ointment. The other rucksack weighs 17.8 pounds and contains a three-man life raft with lanyard with an inflation assembly and CO₂ cylinder, a sea anchor, a dye marker kit, and three sunbonnets.

Temporary Stowage Bags — Each crewman has a 3-foot-by-1-foot-by-3-inch bag with inner and outer pocket. It is made of Beta cloth (fiberglass cloth). The inner bag is for temporary stowage of small items; the outer bag is for dry, uncontaminated waste. The bags are stowed in an upper equipment bay locker.

Tools — A rolled pouch contains an emergency wrench, two adapter handles, a crescent wrench, a 4-inch torque set driver, three jack screws, and a 20-inch tether. Each tool has a tether ring, and each is designated by a letter of the alphabet, except the three jack screws. The pouch and

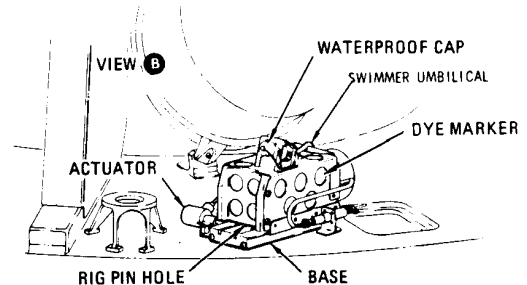
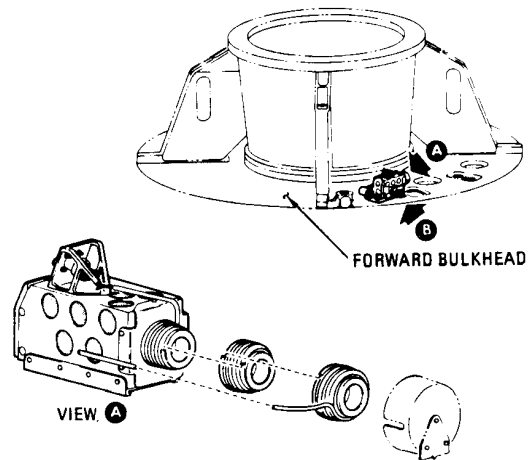
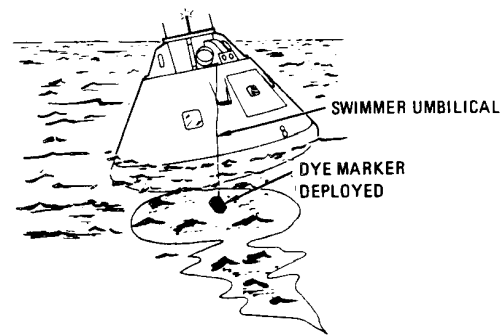

P-97

Dye marker and swimmer umbilical

tools weigh 2.19 pounds. They are stowed in a locker in the aft bulkhead.

Van Allen Belt Dosimeter — The meter is 2-1/2 by 8 by 3 inches and weighs 6 pounds. It measures dose rates to the skin and blood-forming organs. It has two dosimeters (skin and depth), which have ionization chambers as sensors. The meter is mounted in the command module between longeron No. 4 and the hatch. It has three telemetry channels and is powered by 28 volts dc.

DISPLAYS AND CONTROLS

There are hundreds of controls and displays located in the cabin of the Apollo command module. A majority of these are on the main display console, which faces the three crew couches and extends on both sides of them. The console is nearly seven feet long and three feet high, with the two wings each about three feet wide and two feet deep.

The console is the heart of the command module: on it are the switches, dials, meters, circuit breakers, and other controls and displays through which the three-man crew will control the spacecraft and monitor its performance. Crew members can see and operate controls on the console while in their restraint harnesses.

Other displays and controls are placed throughout the cabin in the various equipment bays and on the crew couches. In general, these are controls and displays that do not need frequent attention or are used during parts of the mission when crewmen can be out of the couches. Most of the guidance and navigation equipment is in the lower equipment bay, at the foot of the center couch. This equipment, including the sextant and telescope, is operated by an astronaut standing and using a simple restraint system. The non-time-critical controls of the environmental control system are located in the left-hand equipment bays, while all the controls of the waste management system are on a panel in the right-hand equipment bay. The rotation and translation controllers used for attitude, thrust vector, and translation maneuvers are located on the arms of two crew couches. In addition, a rotation controller can be mounted at the navigation position in the lower equipment bay.

The main display console has been arranged to provide for the expected duties of crew members. These duties fall into the categories of commander, CM pilot, and LM pilot, occupying the left, center, and right couches, respectively. The CM pilot, in the center couch, also acts as the principal navigator.

While each astronaut has a primary responsibility, each Apollo crewman also must know all the controls and displays in the spacecraft. During a mission each might at some time take over the duties of the other crewmen: during sleep or rest periods, while other crewmen are occupied with

- LAUNCH VEHICLE EMERGENCY DETECTION
- FLIGHT ATTITUDE
- MISSION SEQUENCE
- VELOCITY CHANGE MONITOR
- ENTRY MONITOR
- PROPELLANT GAUGING
- ENVIRONMENT CONTROL
- COMMUNICATIONS CONTROL
- POWER DISTRIBUTION
- CAUTION & WARNING

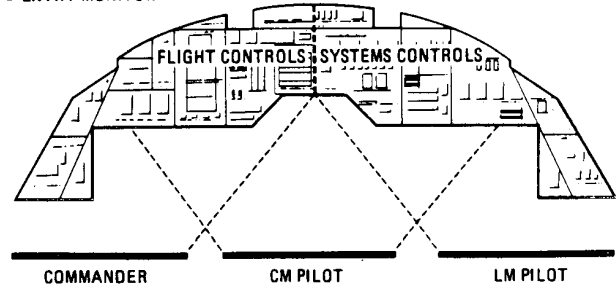

P-98

Main display console

experiments, and, of course, during an emergency.

Flight controls are located on the left-center and left side of the main display console, opposite the commander. These include controls for such subsystems as stabilization and control, propulsion, crew safety, earth landing, and emergency detection. One of two guidance and navigation computer panels also is located here, as are velocity, attitude, and altitude indicators.

The astronaut in the center couch (CM pilot) faces the center of the console, and thus can reach many of the flight controls, as well as the system controls on the right side of the console. Displays and controls directly opposite him include reaction control propellant management, caution and warning, environmental control and cryogenic storage subsystems.

The right-hand (LM pilot's) couch faces the right-center and right side of the console. Communications, electrical control, data storage, and fuel cell subsystem components are located here, as well as service propulsion of subsystem propellant management.

All controls have been designed so they can be operated by astronauts wearing gloves. The controls are predominantly of four basic types: toggle switches, rotary switches with click-stops (detents), thumbwheels, and push buttons. Critical switches are guarded so that they cannot be thrown inadvertently. In addition, some critical controls have locks that must be released before they can be operated.

In any mission, the Apollo crewmen will spend a great deal of their time manipulating controls and monitoring displays on the main display console. Crew duties, broken down by mission phase, are determined by NASA and compiled into a checklist for each astronaut. These checklists are part of the flight data file for the mission. This file consists of ten documents divided among three packages. The two smaller packages, called data file bags, each contain two documents and are attached to the outer sides of the left and right couches at about shoulder height. The other six documents are kept in a fiberglass container stowed in the lower equipment bay.

The data file bag on the left couch contains the commander's checklist and the mission flight plan. The bag on the right couch contains the LM pilot's checklist and the mission log, which is used as a backup to the voice recorder log. The data file

container includes the CM pilot's checklist, landmark maps, star charts, orbital maps, an experiment checklist, and spacecraft subsystem data.

Despite the man-hours spent in mission simulators, it would be difficult if not impossible for the astronauts to remember all the procedures required for long-duration mission. The checklists contain the detailed procedures for each phase of the mission.

Among the checklists carried by the astronauts are those for subsystem management. These are compilations of procedures that are common to more than one phase of a mission. These procedures involve system monitoring, periodic checks, and unique functions of the service propulsion, reaction control, electrical power, environmental control, and caution and warning subsystems.

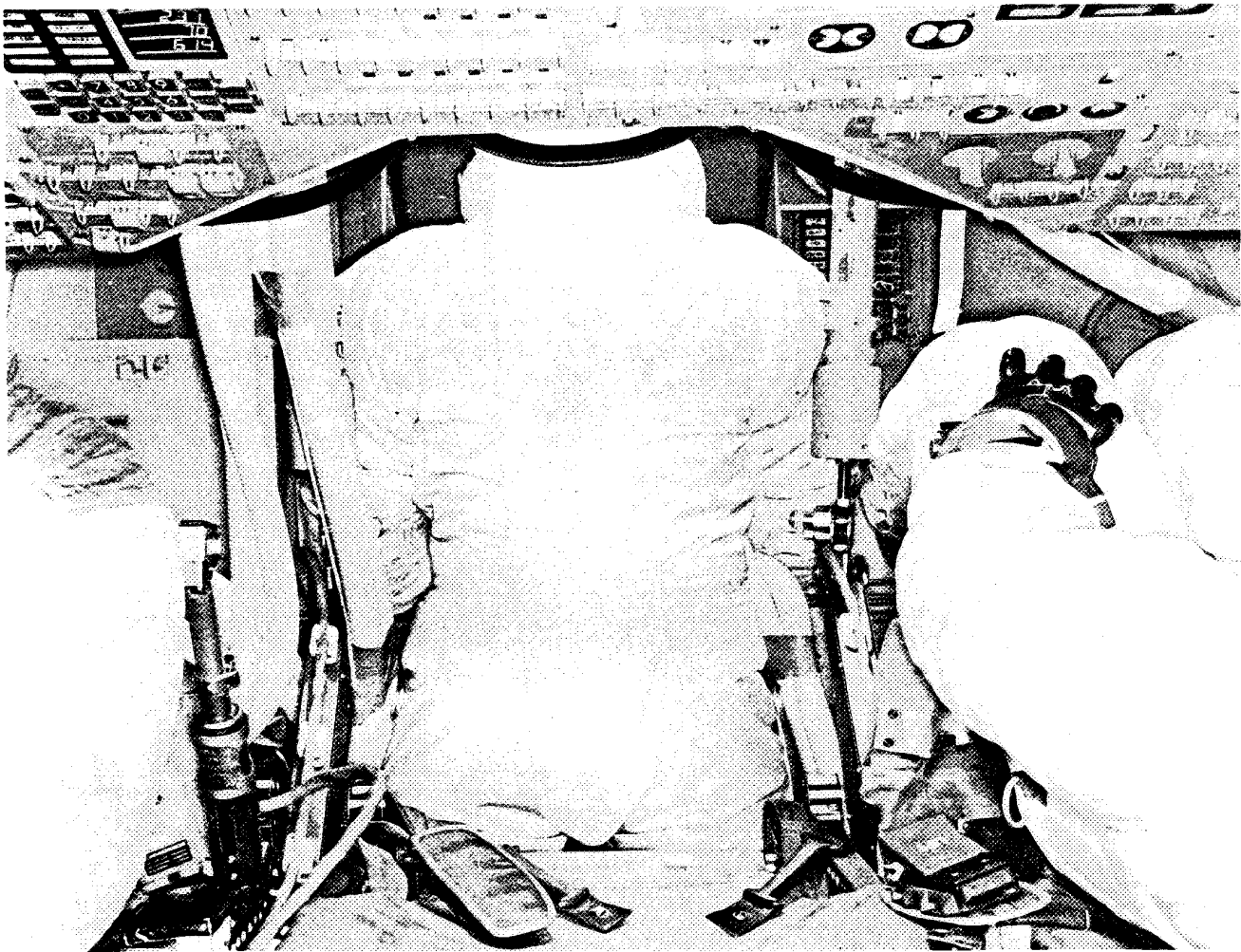

P-99

Astronaut stands at navigation station in lower equipment bay

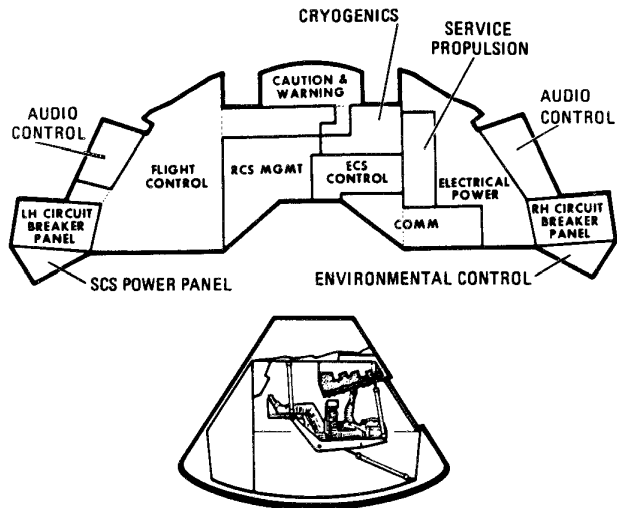

P-100

Grouping of controls and displays

Periodic checks are performed from every hour to every 24 hours, depending on the subsystem, throughout a mission. In addition, other checks or

tests are performed at specific times or events, such as the service propulsion subsystem tests before and after every velocity change.

CAUTION AND WARNING SYSTEM

Critical conditions of most spacecraft systems are monitored by a caution and warning system. A malfunction or out-of-tolerance condition results in illumination of a status light that identifies the abnormality. It also activates the master alarm circuit, which illuminates two master alarm lights on the main display console and one in the lower equipment bay and sends an alarm tone to the astronauts' headsets. The master alarm lights and tone continue until a crewman resets the master alarm circuit. This can be done before the crewmen deal with the problem indicated. The caution and warning system also contains equipment to sense its own malfunctions.

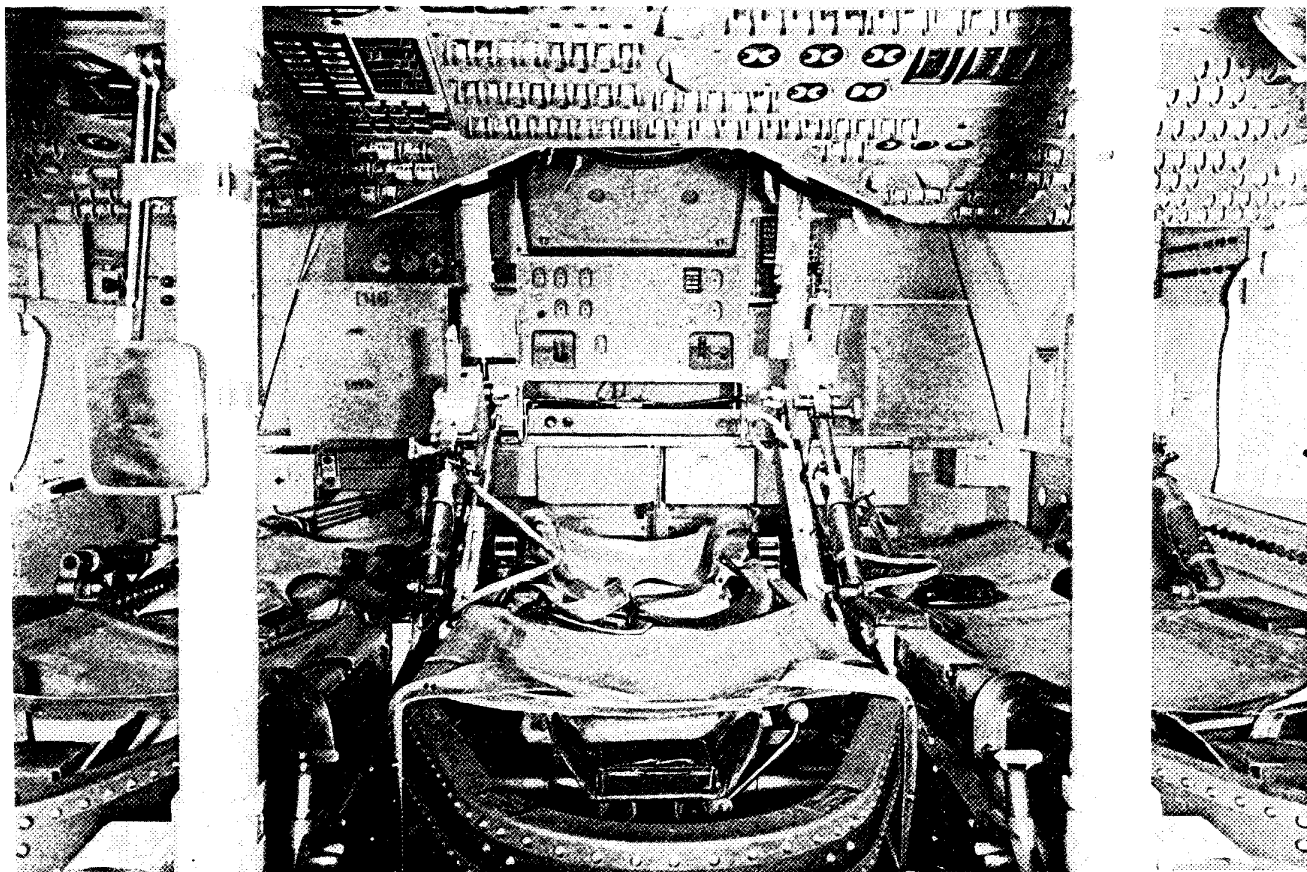

P-102

Panels and crew couches viewed through command module hatch

PAGE NOT COPIED

PAGE IS BLANK

PAGE # 86

DOCKING

The docking subsystem provides the means to connect and disconnect the lunar module and the command module. It is used twice during a normal lunar mission: at the beginning of the translunar flight when the CM docks with the LM, and in lunar orbit when the ascent stage of the lunar module docks with the CM.

Docking is achieved by maneuvering one of the modules close enough to the other so that a probe on the CM engages a drogue on the LM. In the first docking, the CM is the maneuvering vehicle and the LM the passive one; in the second docking the LM ascent stage is active and the CM passive.

The probe, drogue, tension tie, and a docking ring are the principal components of the docking subsystem. Each module also contains a docking pressure hatch and a tunnel through which the astronauts will transfer from one vehicle to the other.

The docking maneuvers are controlled by the commander through short bursts of the reaction control engines on the active vehicle. He is aided in maneuvering his craft by the crewman alignment sight, an optical device something like the range finder of a camera which is mounted at a rendezvous window.

Before the docking maneuvers begin a crewman in the CM activates a switch which extends the probe. When the probe comes into contact with the drogue, it is guided into the socket at the bottom of the drogue. Three capture latches in the probe head then hold the two modules together.

A crewman then activates the probe retraction device (a nitrogen pressure system located in the probe) which automatically pulls the LM and CM together. At contact 12 latches mounted on the CM docking ring are automatically activated to form a pressure-tight seal between the two modules.

A CM crewman then equalizes the pressure between the LM and CM tunnels through a valve provided for the purpose and removes the CM's docking hatch. After removing the hatch, he first checks all the docking ring latches to make sure they are engaged (locking of any 3 of the 12 latches is sufficient to assure a pressure-tight seal and allow entry into tunnel), and manually locks those that aren't. He then connects the two electrical umbilicals (stowed in the LM) to the CM ring connectors, providing power from the CM to the LM. The probe and drogue are then removed and passed down into the CM along with the hatch. Finally, he operates the valve in the LM docking hatch to equalize the

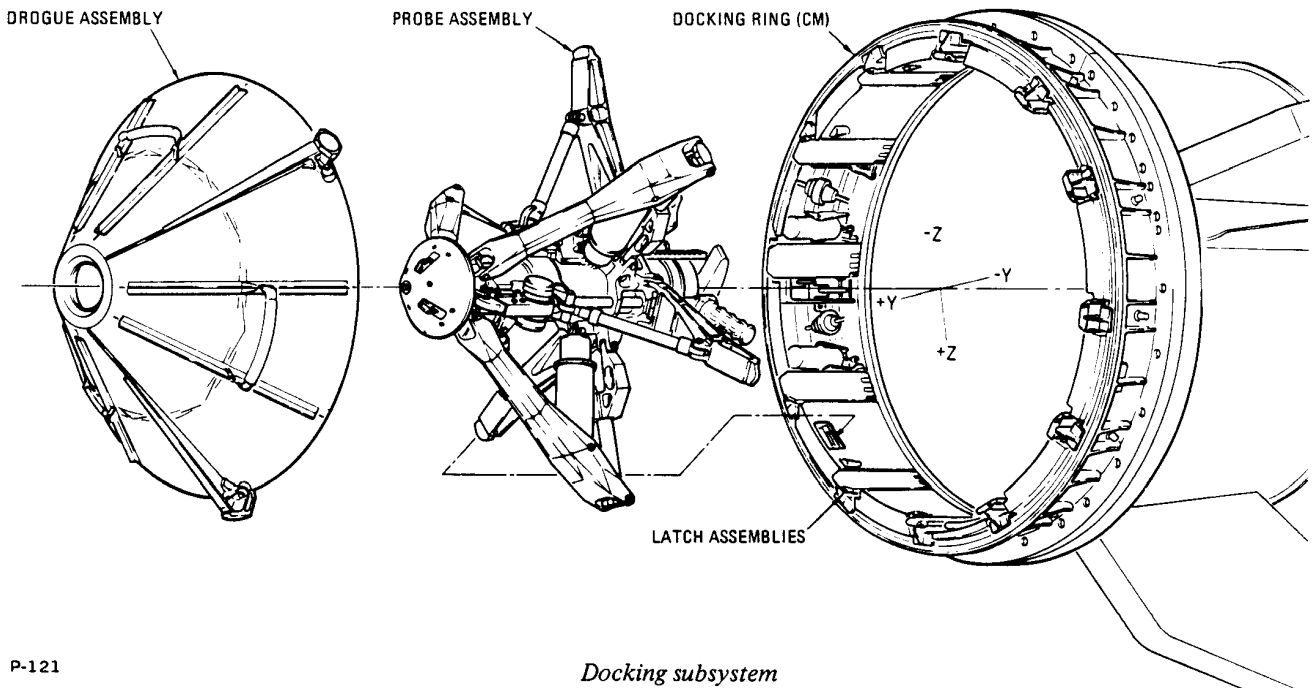

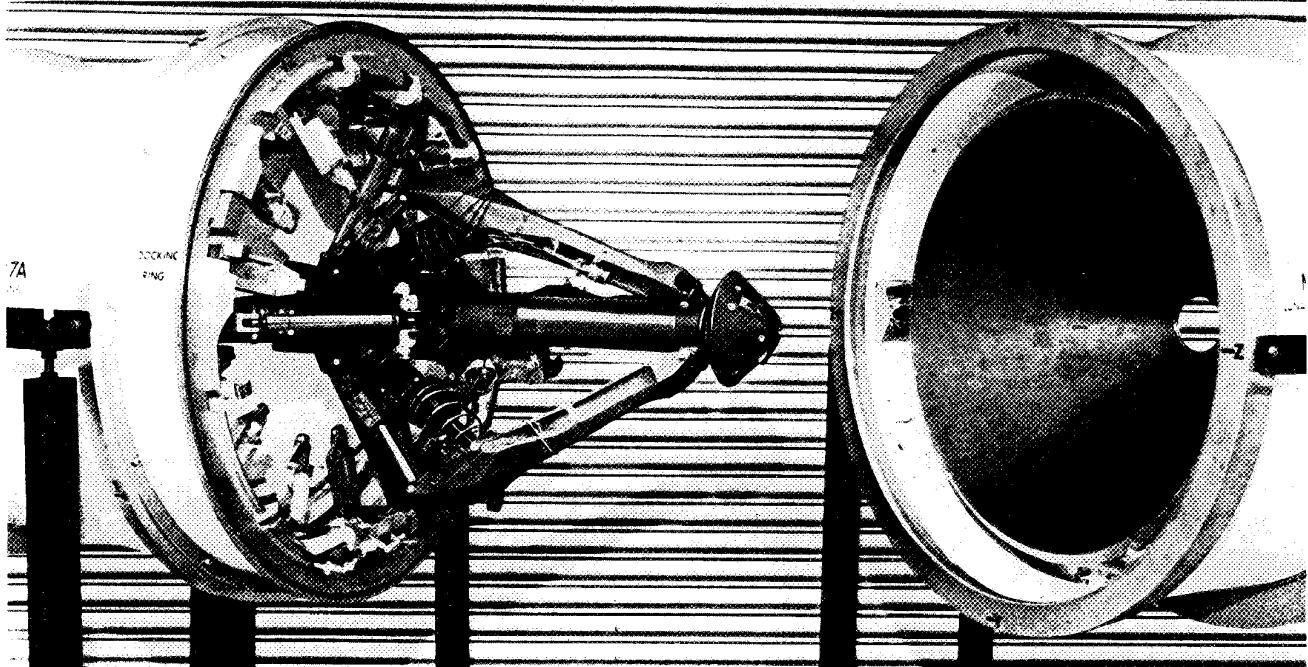

P-122

Mockup of docking subsystem

pressure in the LM. The LM hatch can then be opened; this is hinged to swing inward into the LM crew compartment.

In the first docking, the probe and drogue will not be removed, nor will the LM hatch be opened. The CM crewman will remove the CM hatch, check the locking latches, connect the umbilicals, and replace the CM hatch.

Once in orbit around the moon, the passage between the two modules is opened, the hatch, probe and drogue are removed, and two astronauts transfer into the LM. The remaining CM crewman then passes the drogue back to an LM crewman and it is re-installed in the tunnel. The CM crewman re-installs the probe and disconnects the LM/CM umbilicals for stowage in the tunnel area, manually cocks all the 12 ring latches, and then closes and seals both hatches. The two vehicles are separated for lunar descent through remote electrical release of latches on the probe assembly.

In the second docking, the LM is the maneuvering or active vehicle, but the operations are otherwise similar. The CM crewman must remove the CM hatch, check the latches, and remove the probe into the CM. An LM crewman opens the LM hatch and removes the drogue to open the tunnel.

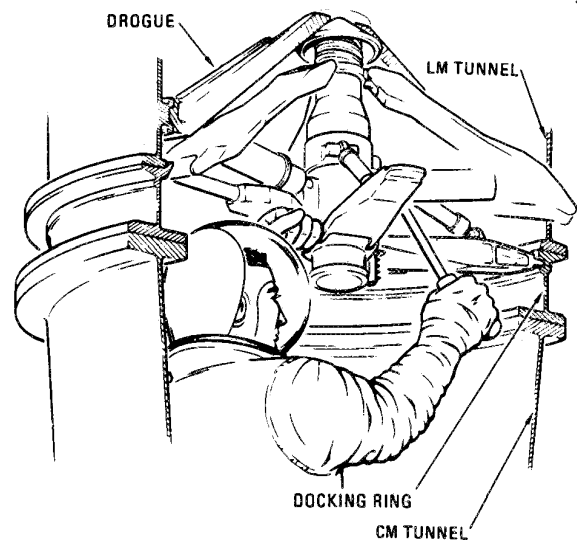

P-123

Operation of ratchet assembly

After all equipment has been transferred from the LM to the CM, the probe and drogue are stowed in the LM, since they are no longer needed. Both hatches are then replaced and sealed and the modules are ready for separation.

In this case, separation is accomplished by firing an explosive train located around the circumference

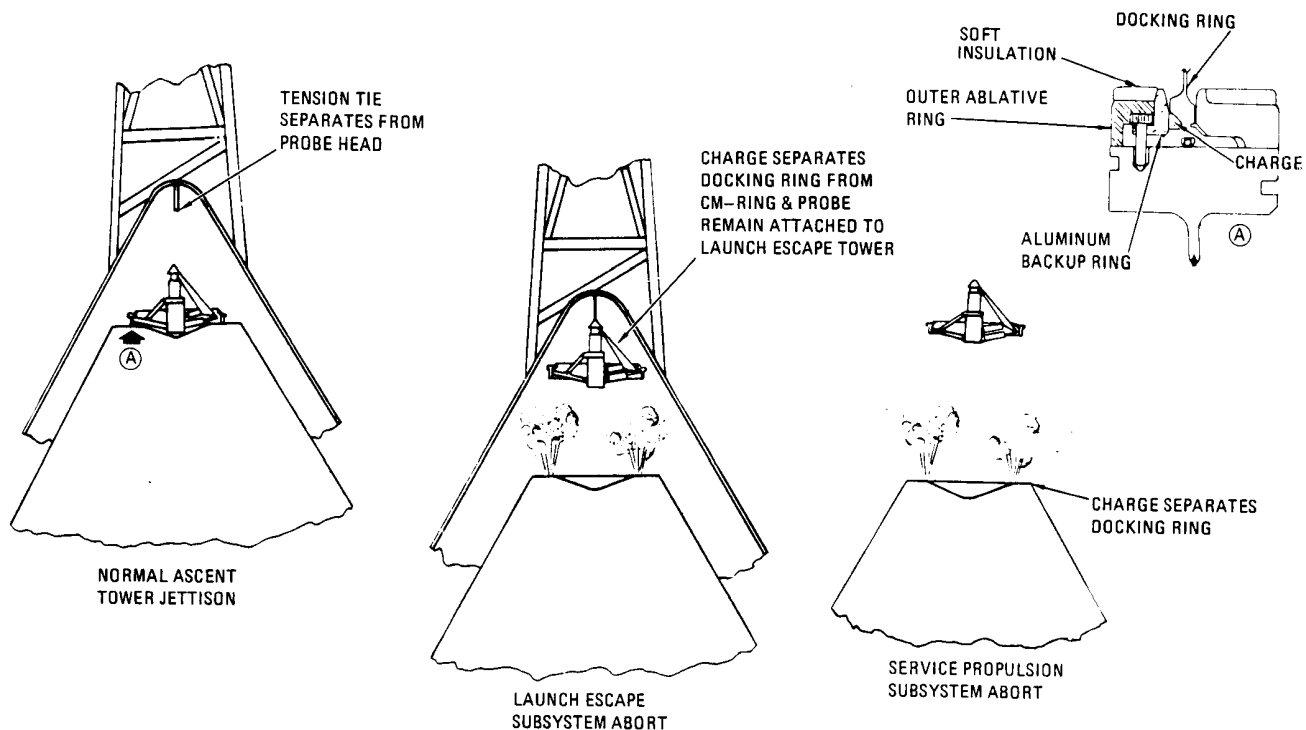

P-124

Modes of separating probe

of the docking ring. This separates the entire docking ring from the CM and provides enough impetus to separate the modules. The docking ring remains attached to the LM ascent stage, which remains in orbit around the moon.

EQUIPMENT

Probe—Consists of aluminum inner and outer cylinders sized to allow a maximum of 10 inches of travel of the inner cylinder, and a probe head gimbal-mounted on the inner cylinder. The probe head is self-centering and houses the three capture latches. The probe is mounted at three points to the docking ring by a support structure attached to the outer cylinder and is designed to fold so that it can be removed from either LM or CM side. Its components include pitch arms and tension linkages, shock attenuators, extension latch assembly, capture latches, ratchet assembly, a retraction system, and probe umbilicals.

Shock Attenuators—These are piston, variable orifice, fluid displacement units hermetically sealed with a metal bellows. They absorb the shock of impact during docking.

Pitch Arms and Tension Linkages—These make contact with the drogue surface for CM/LM alignment and shock attenuation; the contacting surfaces of the pitch arms are contoured to match the curvature of the drogue. The tension links transmit loads to the shock attenuators.

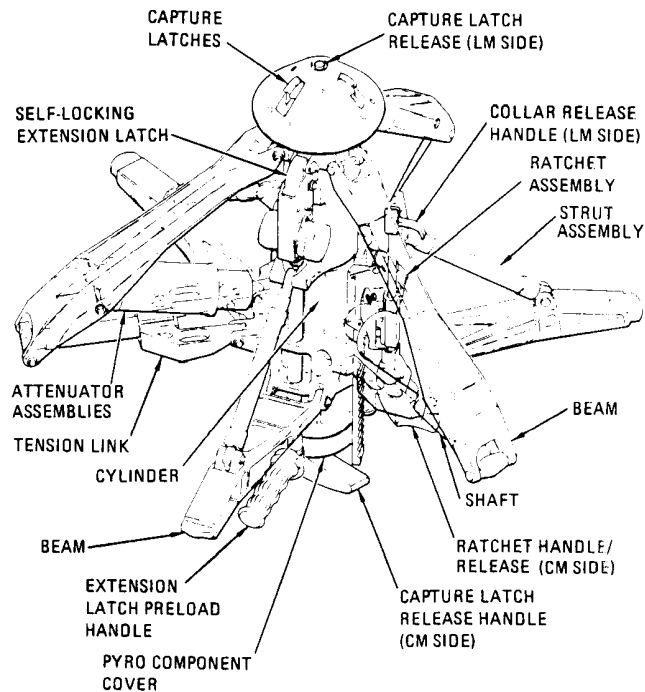

P-125

Probe assembly

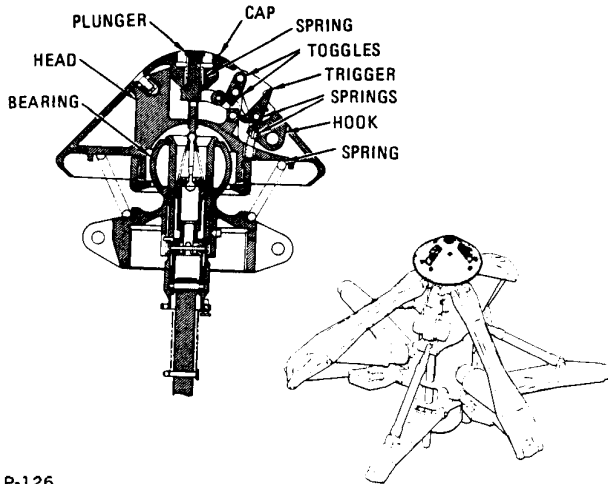

P-126

Capture latch assembly

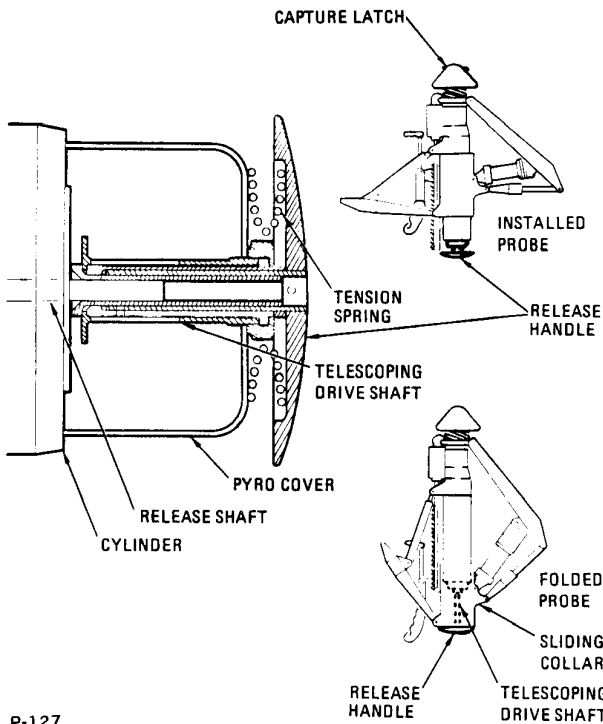

P-127

Capture latch release

Extension Latch Assembly—This engages and retains the probe in a fully retracted position after docking. It is released remotely from the CM to allow probe extension.

Capture Latches—These are mounted in the probe head and engage automatically when the probe head centers and bottoms in the drogue. Engagement of these latches operates a switch on the probe which initiates automatic operation of the retraction mechanism. The capture latches can be

released remotely from the CM or by a manual release handle from the CM side. They can also be released from the LM side by depressing the center button in the probe head.

Ratchet Assembly—This mechanism provides a hold for handling the probe, and performs the ratcheting operation to install the probe support arms. A handle is provided from either the CM or LM side to unlock the ratchet sliding collar for folding and removing the probe.

Retraction System—This is a cold gas system pressurized from four hermetically sealed nitrogen bottles located inside the probe body. When the gas pressure is released it compresses a piston with sufficient force to draw the LM to the CM, compress the interface seal, and engage the locking latches. The retraction system is activated automatically by capture latch engagement into the drogue opening or manually by a CM crewman.

Probe Umbilicals—The microdot connectors and harness assemblies are provided for probe instrumentation and power. The connectors are installed on the side of the docking ring and can be mated and demated from either the CM or LM side. During probe removal and stowing, the umbilical connectors are attached to receptacles on the probe support beams.

Drogue Assembly—The drogue consists of an internal conical surface facing the CM, a support structure and mounting provisions, and a locking mechanism that prevents it from turning during the docking maneuvers. It is made of aluminum honeycomb with aluminum support beams. The drogue may be unlocked and removed from either side.

Docking Ring—This is an aluminum structure bolted to the CM tunnel just forward of the top hatch. It contains seals and the shaped charge for final separation. It also serves as the mounting point for the probe and docking latches. The docking ring must withstand all loads from docking and from course corrections, and must maintain proper alignment of the docked vehicles. The ring also contains a covered passageway for the electrical harnesses and connections for attaching the umbilicals between the modules.

Docking Latches—The 12 docking latches are spaced an equal distance around the inner peri-

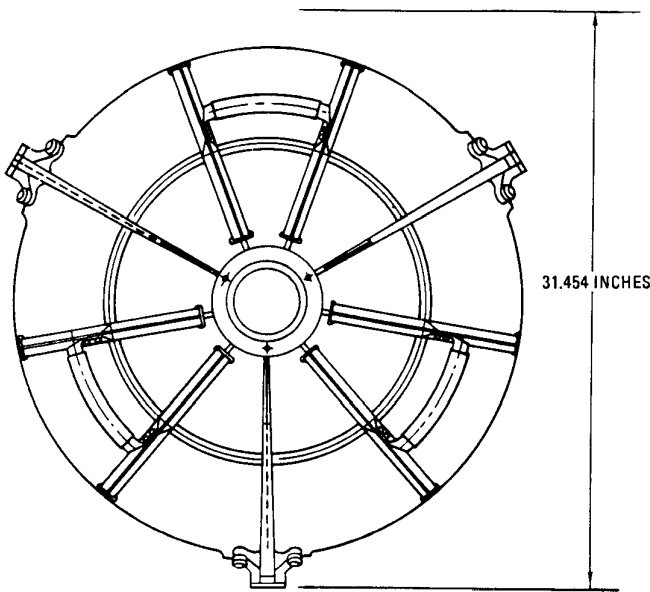

P-128

Drogue assembly

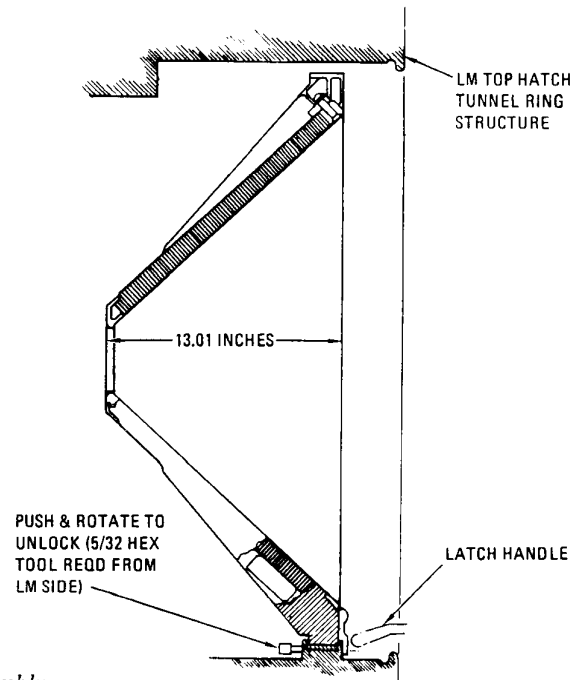

phery of the docking ring. The latches automatically seek and engage the back surface of the LM docking flange. The latch trigger mechanism is activated by contact with the flange. The latch will retract its hook, seat it on the back of the flange, and compress the docking seals. The latches are released manually by a crewman pulling the handle two times. This relieves the load from the hook and cocks the mechanism for the next docking engagement.

Docking Seals—These seals are round and hollow and made of a silicon material; they compress when the two modules come together to form a pressure-tight seal.

Umbilicals—Two electrical umbilicals are attached to stowage connectors on the LM tunnel wall so that they are clear of the probe and drogue supports during docking. The umbilicals can be reached from the CM tunnel and are connected to the receptacles on the CM docking ring before LM withdrawal.

Tunnel Hatches—The hatch at the forward end of the CM can be opened from either side (by a handle on the CM side and with a tool from the LM side), but can be removed only into the CM. The hatch contains a pressure equalization valve which can be operated from either side to equalize the pressure in the tunnel and LM before

removing the hatch. The LM docking hatch is located at the lower end of the LM tunnel and is not removable; it swings down into the LM crew compartment. It also can be opened from either side, and has a pressure dump valve. Although the valve's primary function is to release pressure from the LM cabin, it can also be used to equalize pressure in the tunnel.

Passive Tension Tie—A tension-type bolt arrangement connecting the probe and the boost protective cover. During normal flight, the attaching pins are sheared in the probe head, leaving the probe intact for docking. During an abort, a pyrotechnic charge separates the docking ring, allowing the launch escape tower to take the ring and probe with it.

Pyrotechnic Charge—This is a mild detonating fuse located around the periphery of the docking ring. When fired, the charge separates the ring structure between the forward heat shield and the probe mounting, leaving all docking hardware with the LM. The charge is initiated by a signal from the CM. The charge normally is fired for final separation of the LM ascent stage, just before the CSM is injected on the transearth flight. It also would be fired during an abort, and the docking hardware would be carried away by the launch escape subsystem.

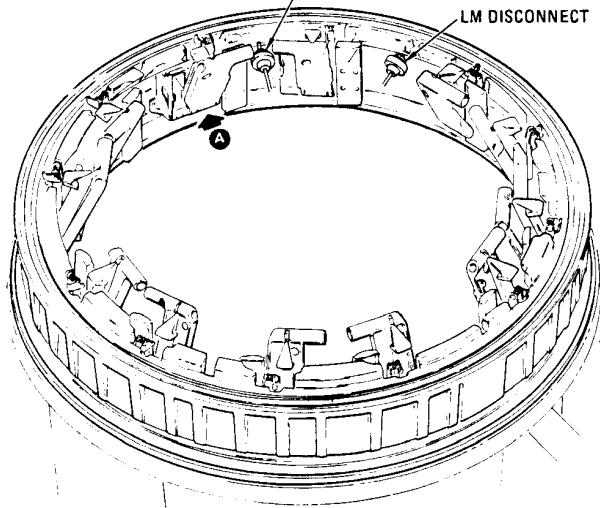
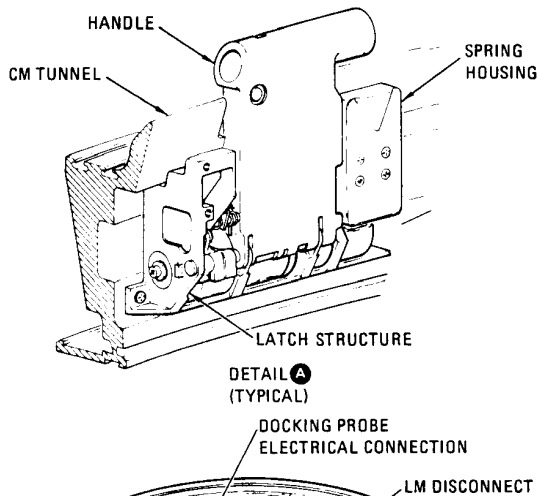

P-129

Docking latches

Crewman Optical Alignment Sight—This is used to help astronauts align the maneuvering module with the passive one. It is a collimator-type device that provides the astronaut with a fixed line-of-sight reference image. When viewed through the rendezvous window, the image appears to be the same distance away as the target. It is about 8 inches long, can be mounted near either rendezvous window, and has a control to permit adjustment for proper brightness against any background lighting conditions. The operator controls firing of the reaction control engines so as to keep the projected image superimposed on the passive module target. Range and rate of closure are determined by the size relationship between the image and the target. The adjustable light source projects the image from within its housing to the crewman's right eye by means of a beam splitter or combining glass. Though the image is projected to the right eye only, the crewman sights with both eyes open.

Single-eye projection keeps the system small and eliminates apparent parallax of the projected image caused by focusing and by convergence when sighting during the final docking phase. Sideward motion of the astronaut's head during sighting will not affect the system.

Docking Targets—These are mounted in a window of the CM and LM to aid in docking maneuvers. The LM active docking target is mounted in the right rendezvous window of the CM. Its base is 8 inches in diameter and contains green electroluminescent lamps and a black stripe pattern on the first. An upright support at a right angle to base contains a red incandescent lamp. The docking target in the LM is similar but about twice the size.

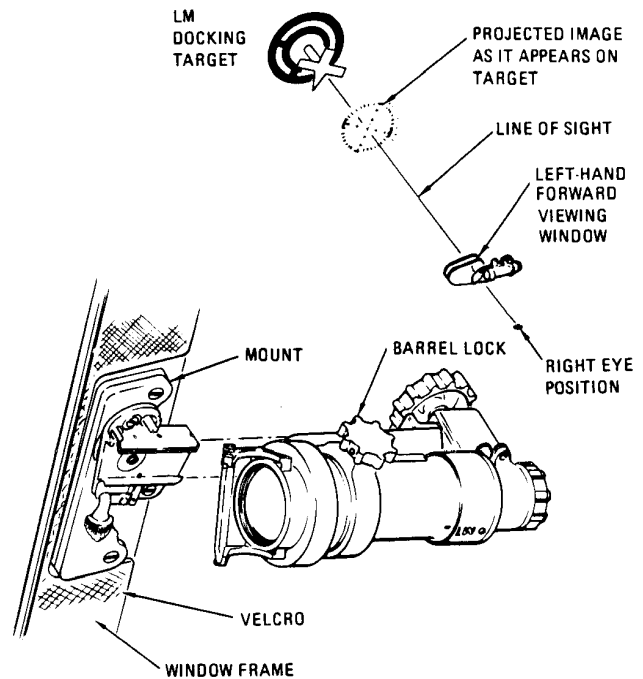

P-130

Crewman optical alignment sight

EARTH LANDING

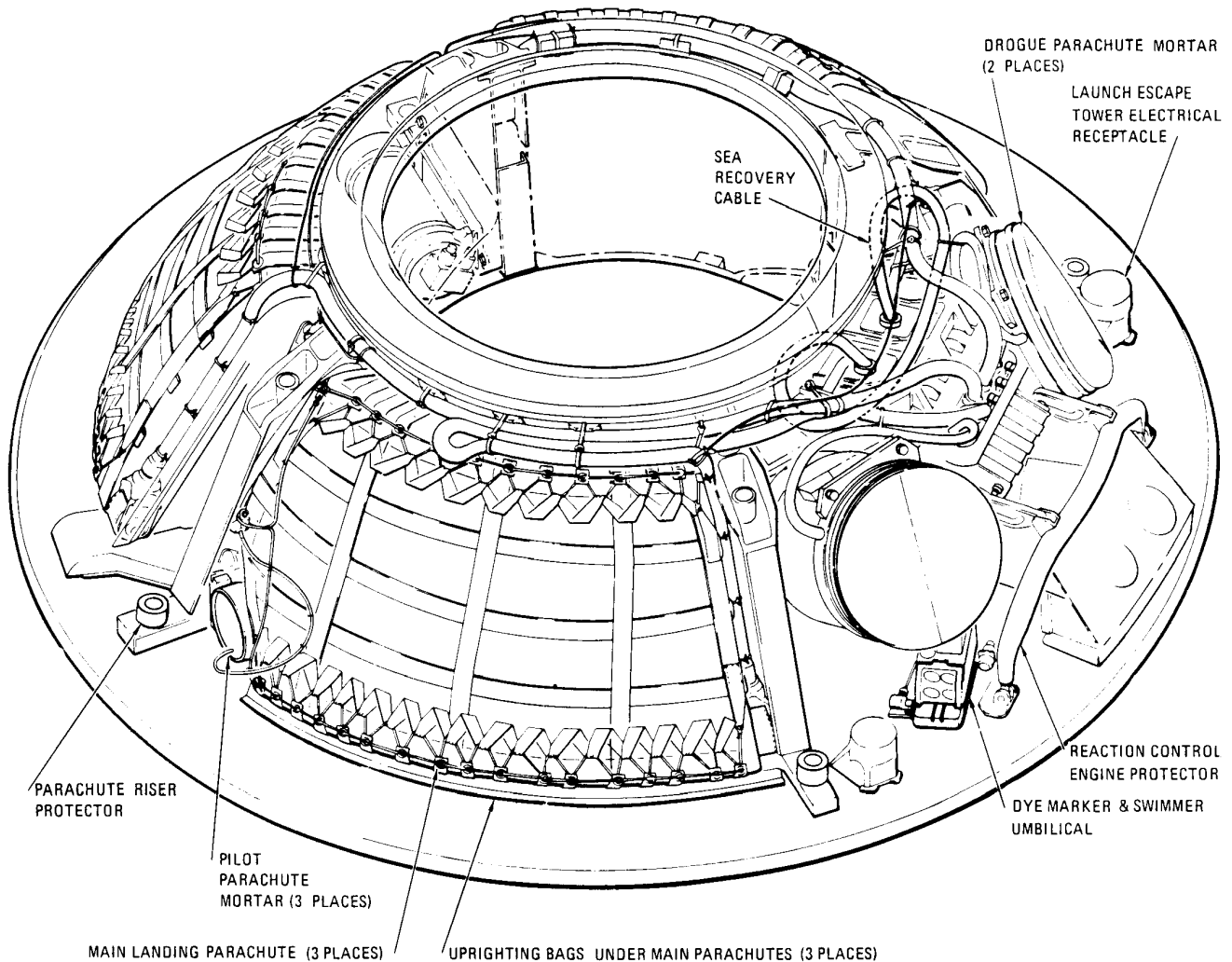

P-131

Location of main components of earth landing subsystem

The earth landing subsystem provides a safe landing for the astronauts and the command module. Several recovery aids which are activated after splashdown are part of the subsystem. Operation of the subsystem normally is automatic, timed and activated by the sequential control system. There are, however, backup manual controls for astronaut operation.

For normal entry, the subsystem operation begins with jettison of the forward heat shield when the CM descends to about 24,000 feet. About 1-1/2 seconds later the two drogue parachutes are deployed to orient the module properly and to provide initial deceleration. At about 10,000 feet, the

drogue parachutes are released and the three pilot parachutes are deployed; these pull the main parachutes from the forward section of the CM. The main parachutes hold the CM at an angle of 27-1/2 degrees so the module will hit the water on its "toe," which will produce water penetration at the least impact load. If one of the main parachutes fails to open, the remaining two will be able to land the CM safely.

This sequence of operations differs slightly for an abort. In that case, the forward heat shield is jettisoned 0.4 second after jettisoning of the launch escape tower. The drogue chutes are then deployed 1.6 seconds later. For low-altitude aborts the main